

# Product transfer system.

In hygienic design for horizontal packaging machines

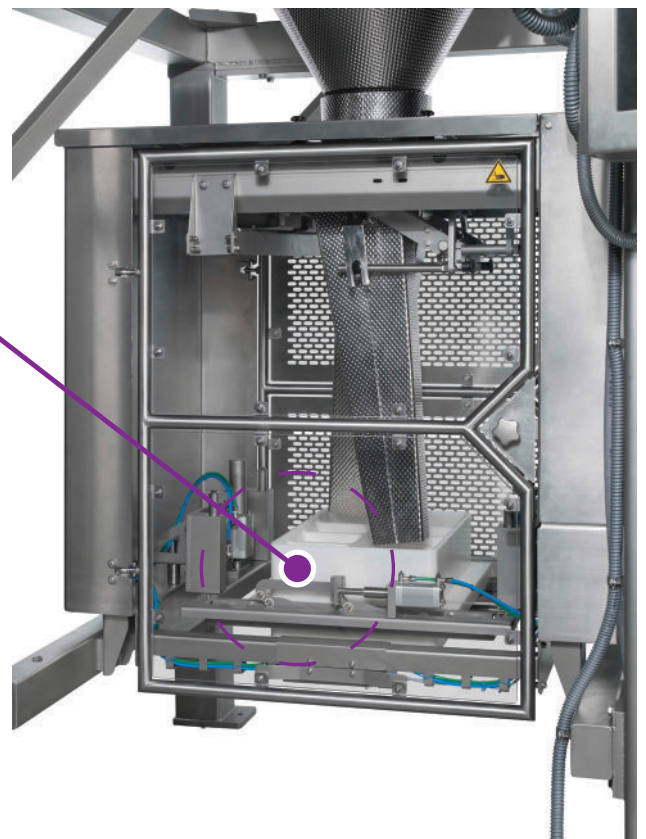
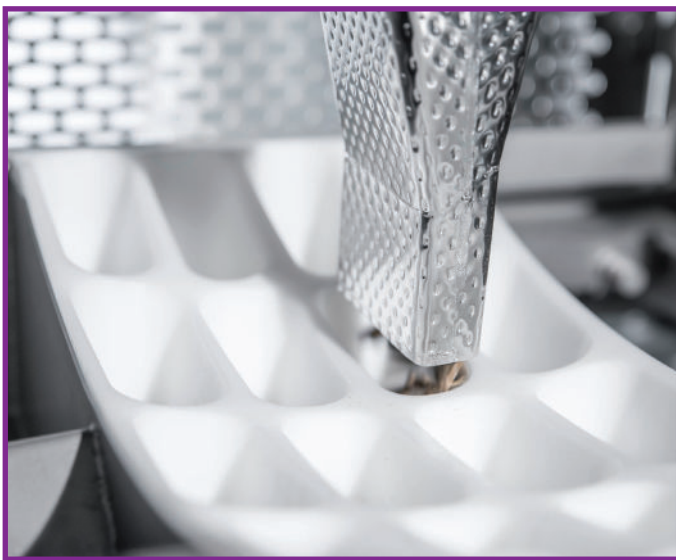

## Function.

- > Controlled product feeding from combination weigher or through elevators, bucket conveyors, belts, vibration systems
- > Synchronized transfer to the horizontal packaging machine

## Safe.

- > Servo driven swiveling- and positioning unit
- > „Teach-in“ based format- and product change
- > Format change without tools
- > Easy operation with graphic menu guidance on a multilingual colour touch screen of combination weigher

## Flexible.

- > Suitable for the widest range of products
- > Modular design

## Efficient.

- > Easy storage of product-related recipes
- > Easy troubleshooting with a plain-text display
- > Long-lived maintenance-free drives
- > Short cleaning times through Sanitary Design, sealed construction, quick exchangeable size parts

# Product transfer system.

In hygienic design for horizontal packaging machines

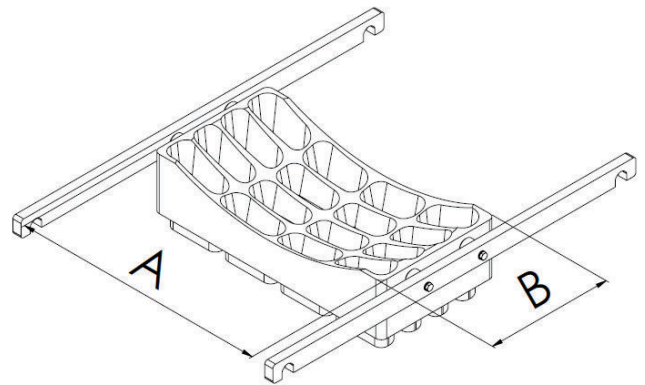
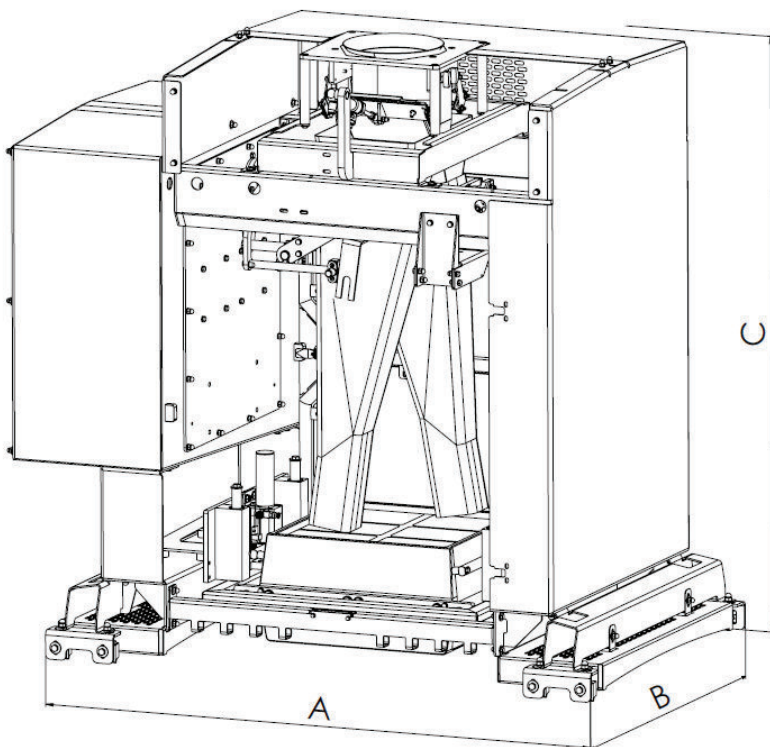

## Technical data:

All indications are depending on product, dosing, film, production and ambient conditions. Technical modifications are subject to change.

Type	Number Swiveling arms	Approx. measurements			Max. output
		A	B	C	
<b>1. Product transfer system</b>					
Single	1	820 mm	1.215 mm	1.250 mm	60 fillings/min.
Duplex	2	820 mm	1.215 mm	1.250 mm	120 fillings/min.
<b>2. Tray- or thermoforming format</b>		240 - 450 mm	120 - 450 (600) mm		

**Bin volume:**  
Product specific

**Protection:**  
IP 65

**Control:**  
Industrial PC with coloured Touch Screen and integrated error diagnosis system and statistic programme

**Special Design:**  
For sticky and fragile products

**Material:**  
Stainless steel for all parts in contact with product

**Design:**  
Single and Duplex

